

MZ18B

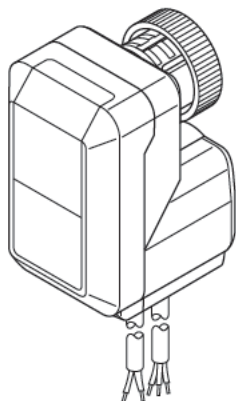

3-point Valve Actuator

The MZ18B actuator is specifically designed to provide 3-point control together with the VZ22, VZ32 and VZ42 series of small valves.

The MZ18B actuator is used in fan-coil-units, induction units, small reheaters and recoolers and for zone control applications.

The absence of endswitches or feedback potentiometer ensures longtime reliability.

SPECIFICATIONS

Part number	.845-5101
Input voltage	.24 Vac + 10 % ...-30 %; 50/60 Hz
Power consumption	0,7 VA
Control mode	floating (3-point)
Stroke	6.5 mm
Running time	150 s at 50 Hz 120 s at 60 Hz
Stem force	180 N (for valves DN 15-20)
Protection standard	IP 43 in accordance with EN 60529
Insulation class	III in accordance with EN 60730
Connection cable	1.5 m
Coupling ring	M 30 x 1,5
Ambient operating temperature limits	0-60 °C
Weight	0,4 kg
Suitable valves	see table on last page

DIMENSIONS mm (in)

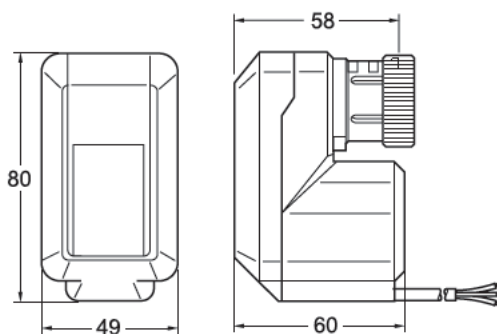

FUNCTION

The movement of the electric actuator is produced by a screw spindle which is driven in both directions by a synchronous motor through a set of gears.

A magnetic clutch limits the torque of the gear assembly and the driving force of the actuator. The actuator is fixed to the valve body by means of a coupling ring requiring no tools for mounting.

The actuator is maintenance-free and supplied completely with a ready-to-wire connecting cable.

The movement of the actuator stem indicates whether the valve is opening or closing. (Fig. 1)

FUNCTION

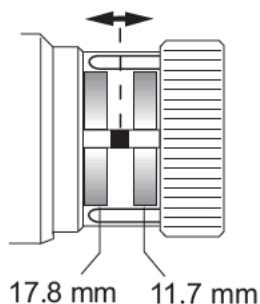

Fig. 1

MOUNTING

Mounting Position

The actuator may only be mounted beside or above the valve. Adjust the valve in the right position before mounting the actuator. (Fig. 2)

Mounting

Before the actuator is fixed to the valve, the adjustment cap must be removed. Make sure that the actuator is in the open position (factory supplied position) before fixing the actuator to the valve body. (Fig. 3)

The actuator must be mounted by hand. Don't use tools or additional forces, because actuator and valve may be damaged.

MOUNTING

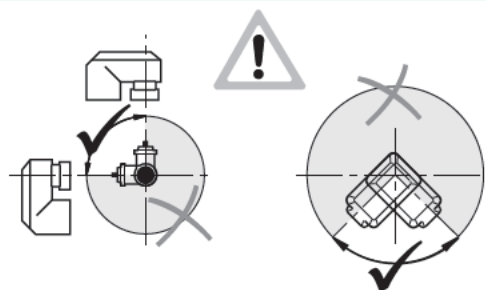

Fig. 2

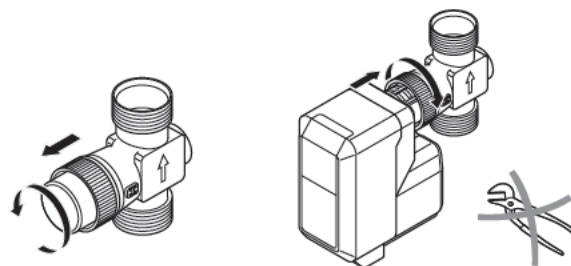

Fig. 3

CONNECTIONS

The electrical installation must comply with the wiring diagram shown in Fig 4.

CONNECTIONS

G0		
White	Green	Brown

Fig. 4

FLOW CAPACITIES AND CLOSE OFF PRESSURE RATINGS

Two-way valves, VZ22

Valve			Close Off Pressure (kPa)with Actuators MZ18A, MZ18B, MZ18L (180 N)
DN	k _{vs}	TAC Part no.	
15	0.16	721-0702	1600
15	0.25	721-0706	1600
15	0.40	721-0710	1600
15	0.63	721-0714	1600
15	1.00	721-0718	1200
15	1.60	721-0722	1200
20	2.50	721-0726	400
20	4.00	721-0730	400

Three-way valves, VZ32

Valve				Close Off Pressure (kPa) with Actuators MZ18A, MZ18B, MZ18L (180 N)
DN	k _{vs} A AB	B AB	TAC Part no.	
15	0.25	0.16	731-0706	800
15	0.40	0.25	731-0710	800
15	0.63	0.40	731-0714	800
15	1.00	0.63	731-0718	250
15	1.60	1.00	731-0722	250
20	2.50	1.60	731-0726	240
20	4.00	2.50	731-0730	240

Three-way valves with bypass, VZ42

Valve				Close Off Pressure (kPa) with Actuators MZ18A, MZ18B, MZ18L (180 N)
DN	k _{vs} A AB	B AB	TAC Part no.	
15	0.25	0.16	741-0706	800
15	0.40	0.25	741-0710	800
15	0.63	0.40	741-0714	800
15	1.00	0.63	741-0718	250
15	1.60	1.00	741-0722	250
20	2.50	1.60	741-0726	240
20	4.00	2.50	741-0730	240

On October 1st, 2009, TAC became the Buildings Business of its parent company Schneider Electric. This document reflects the visual identity of Schneider Electric, however there remains references to TAC as a corporate brand in the body copy. As each document is updated, the body copy will be changed to reflect appropriate corporate brand changes.